



RockBowl Rules

2026

Organization



Support





1. General Rules and Regulations

1.1. About the RockBowl

RockBowl is a question-and-answer game, organized by the Brazilian Committee of Rock Mechanics (CBMR), in which competing teams are challenged to answer technical and non-technical questions, with Rock Mechanics as the central theme.

1.2. Eligibility

- a. The competition is open to undergraduate and graduate students (MSc and PhD) from any university, provided that they are active members of the CBMR/ABMS. Non-Brazilian students must be active members of their respective national rock mechanics committee or ISRM-affiliated society.
- b. All interested teams must submit all completed registration documents to the organizing committee of the event between **May 18, 2026, and May 31st, 2019**.
- c. Team members cannot be more than 35 years old.
- d. There is no cost to participate in the RockBowl.
- e. The professor tutor:
 1. Must have an active affiliation with the University.
 2. Is not required to be a participant in the Congress.
 3. Must not have any affiliation with the event's organizing committee.
 4. Must not have any affiliation with the RockBowl event sponsors.
 5. Must not have served as a judge in any of the last five editions of RockBowl.
- f. The participating teams are responsible for costs associated with travel to the X LARMS / COBRAMSEG 2026. The student teams will be funded with the registration on the X LARMS / COBRAMSEG 2026 and accommodation during the congress.

1.3. Communication

- a. All communication and disclosure rules before and during the game will be held exclusively in English. However, if all registered teams are from Brazil, the competition may be conducted in Portuguese.
- b. Any clarification regarding RockBowl rules must be requested by email to the following e-mail address: rockbowlcbmr@gmail.com
- c. Follow announcements and news about the competition in a dedicated RockBowl page on the X LARMS / COBRAMSEG 2026 website (<https://larms2026.com/>) or on the CBMR website (<https://www.cbmr.com.br/rockbowl/>).
- d. Other communication channels: Instagram ([@rockbowlcbmr](https://www.instagram.com/rockbowlcbmr) or [@cbmr_oficial](https://www.instagram.com/cbmr_oficial)) and [LinkedIn](#).



1.4. Awards

- a. The winning team will receive a trophy for first place.
- b. Each member of the winning team will be awarded a tablet, a champion's certificate, and a first-place medal.
- c. Each member of the runner-up team will receive a second-place medal.
- d. The participant with the best performance in the competition will be awarded a trip to participate in Slope Stability 2026, to be held from October 26th to 29th in Peru. The prize includes: economy-class airfare, event registration and accommodation during the event.

2. Changes in the rules

- a. The competition rules are subject to changes that may be necessary, if approved by the organizing committee of the game.
- b. The organizing committee has the right to cancel the competition at any time up to July 26, 2026.
- c. Any changes in the rules, clarifications, additions and / or game cancellation will be announced:
 1. Via e-mail to all participating teams;
 2. On the RockBowl webpage (<https://www.cbmr.com.br/rockbowl/>);
 3. At the opening of the competition.

3. Registration Guidelines

- a. Call for participation in RockBowl will be announced by the ISRM National Groups, on the CBMR website and on the X LARMS / COBRAMSEG 2026 website. If you are interested in participating and, in case of any questions, the team should contact by e-mail with the Organizing Committee, through rockbowlcbmr@gmail.com.
- b. During the registration period, the organizing committee of RockBowl will contact teams by e-mail.
- c. The registration form will be available online on the RockBowl webpage when registration opens.
- d. All team members must be from the same university. Members from different campuses will be accepted as long as they are from the same university. In exceptional cases, a country team with students from different universities can be accepted upon organizing committee evaluation.



- e. Each group should send ten (10) questions about rock mechanics, according to form model available on the RockBowl webpage with the application materials.
- f. Application should be filled out and document files uploaded through RockBowl online or pdf registration forms. Documents required are listed below:
 - 1. Application form duly completed by all participants of the team;
 - 2. Proof of enrollment at University (the current semester or year) of all participants of the team;
 - 3. Face photograph of each participant and the professor tutor (3x4 ratio);
 - 4. University or team logo. The team logo is subject to approval by the Organizing Committee. Any logo containing content unrelated to the purpose of the competition, such as political, religious, or ideological content, is strictly prohibited;
 - 5. Questionnaire Form completed.
 - 6. A signed statement from the professor tutor confirming their role as team representative, including their name, affiliated university, and the names of the team members.
- g. The selected teams will be published on the RockBowl webpage at the end of the registration period.
- h. Teams that do not comply with all the rules mentioned in this item will be automatically disqualified.
- i. If the team is unable to complete the registration form, the registration may be submitted via email to rockbowlcbmr@gmail.com, provided that all the aforementioned documentation is included. The subject line of the email must follow the format: "RockBowl 2026 Registration – <team name>".

4. Qualification

- a. Sixteen (16) teams will qualify to participate in knockout stage of the tournament.
- b. The qualification will occur in order of online registration. If two or more teams from the same university / country enroll, the first to sign up is automatically qualified and the others will be held in stand-by, honoring the order of registration.
- c. The availability of vacancies in the competition for the teams in the waiting list may occur in case of withdrawal of qualified teams or if there are not sixteen (16) teams automatically qualified according to the item 4.b.

5. Important Dates

- a. The initial date of the application period of the teams will be **May 18, 2026**.
- b. The final date of the application period will be **June 5, 2026**.
- c. The announcement of the selected teams will be until by **June 12, 2026**.
- d. Cancellations should be informed by **June 19, 2026**, allowing the call for new teams from the waiting list as well as adjustment of rounds.
 1. The announcement of teams from the waiting list, in the event of any withdrawals, will be on **June 22, 2026**.
 2. The deadline for teams from the waiting list to confirm participation will be **June 29, 2026**.
- e. The games will take place from **August 26 to August 27, 2026**, at the Centro Internacional de Convenções do Brasil (CICB), in Brasília, Brazil.

6. Rules of Competition

6.1. Game format and general rules for the competition

- a. A maximum of sixteen (16) teams may enroll, as set out in item 4 of this regulation. The competition will consist of a knockout system, in which one team is eliminated in each match.
- b. If the number of registered teams is less than sixteen (16), adjustments to the rules will be made and released by amending the regulation.
- c. Definition of rounds: the pairs of opposing teams in the first round of the competition (round of sixteen) will be drawn by lot, to be held in the presence of the teams.
- d. In case of non-attendance of a team at the date and time of the draw of team groups, the team will be set to the last spot available and the remaining teams will be adjusted.
- e. If a team does not attend the game after the draw of the team groups, the opposing team moves to the next phase automatically.
- f. The draw for the sets of questions for each round will be held at the beginning of each game.
- g. During the competition, any political, partisan, ideological, or religious expression of any kind, or any conduct deemed offensive or inconsistent with the spirit and nature of the competition, is prohibited on the part of team members and their supporters. This includes, but is not limited to, the use of clothing, hats, banners, flags, posters, and sound signals.

h. The scheme of the team groups is illustrated in Figure 1. The conceived arrangement of teams, moderator, judges and officials of the game (control), as well as display devices for teams and audience, can be seen in Figure 2.

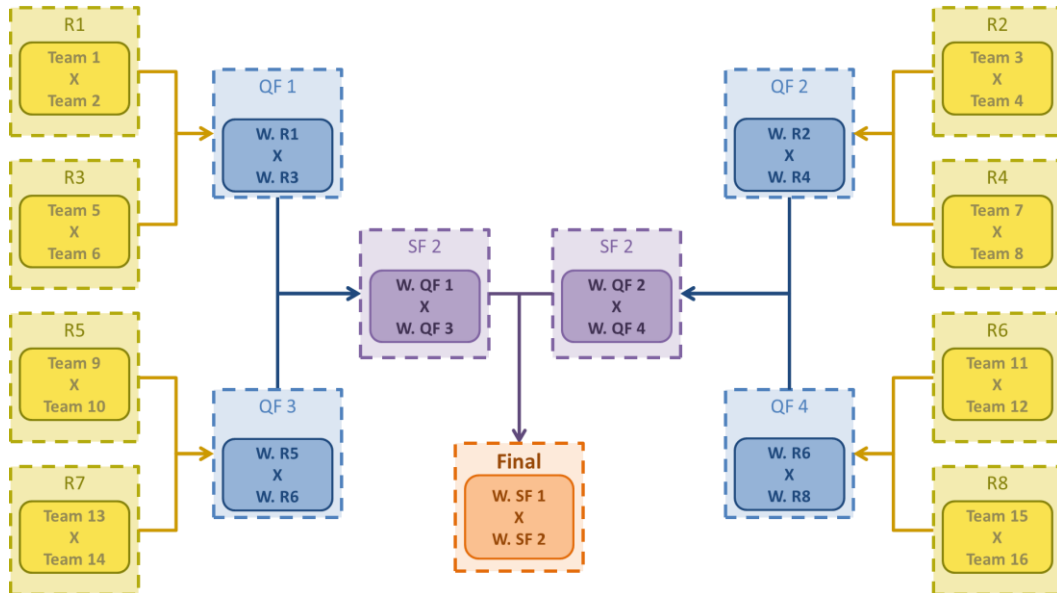

Figure 1. Configuration of team groups of the RockBowl 2026 (R: round, QF: quarter final, SF: semifinal and W: Winner).

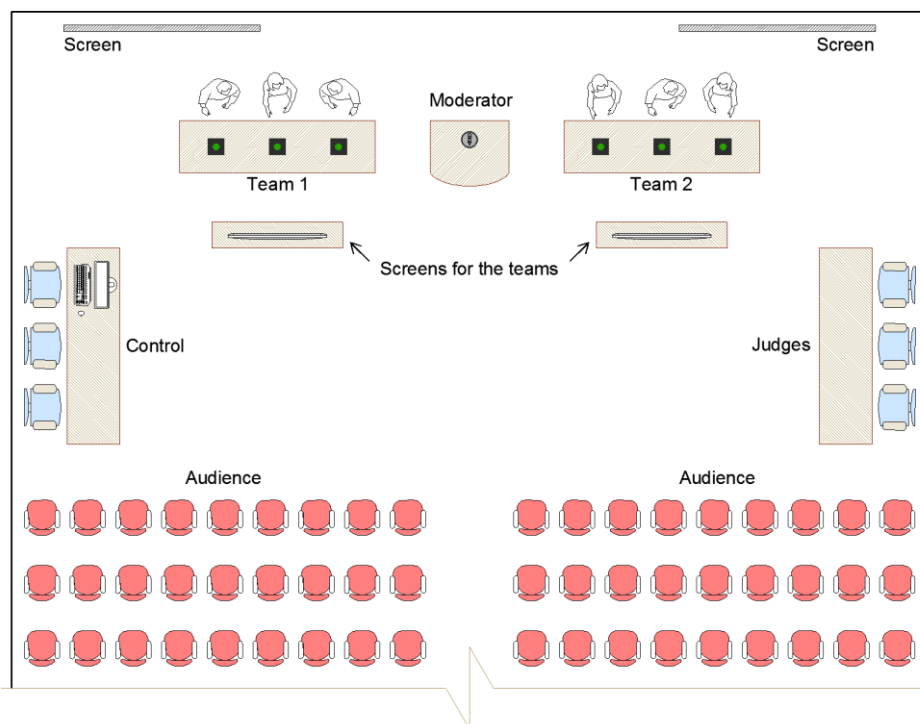

Figure 2. Idealized arrangement of RockBowl 2026 environment.



6.2. Tournament officials

- a. Judges: each dispute shall have three (3) judges with no links with the applied teams. All decisions made by the judges will be considered as final decisions.
- b. Moderator: the moderator reads the questions, consult the judges when necessary to assess whether the answers are correct, grants and deducts points, and strengthens the rules of the competition.
- c. Game inspector: there will be a game inspector for each team during each round in order to ensure that the rules are complied with, and any violations are reported by the moderator.

6.3. Equipment

- a. In every game, each player will have a buzzer positioned in front of them. The buzzer consists of an electronic device installed on the counter that determines which player presses the button first to answer the question.
 1. Prior to each match, the buzzer system will be tested, and in the event of any malfunction, the equipment will be replaced;
 2. After the start of the match, each participant is responsible for the proper operation of their buzzer during the game;
 3. If a buzzer presents problems, only the general current question or the last general question can be repeated, subject to moderator analysis, if the malfunction impacted the game at that point.
- b. The game time will be controlled by a chronometer clearly visible by both teams.
- c. Calculators, reference materials, and any electronic devices are not allowed. There will be no questions involving calculations.
- d. The points count per team as well as individual player, will be performed automatically by the software responsible for managing the game. The software also controls the time for the answers.

6.4. Participants

- a. a. A team shall consist of a minimum of two (2) and a maximum of three (3) participants who meet the eligibility requirements. The following conditions apply:
 1. The main team may include a maximum of one doctoral student.
 2. The maximum age of participants is 35 years by the date of the event.
 3. Teams may play sparingly, with a minimum of two (2) players.
 4. Each team must designate a captain, who will be responsible for uploading the team registration documents and for all communication with the organizing committee of the game.



5. Each team must indicate, at the time of registration, the name of the professor tutor responsible for the team.
- b. The players and fans are responsible for their conduct during the tournament. Any acts of dishonesty or that are inconsistent with the spirit of the competition, detected by officers of the game, imply exclusion of the dispute. Please see the section on ethics and conduct.

6.5. Time

- a. Delays of more than ten (10) minutes of the scheduled time will result in disqualification of the team.
- b. The qualifying rounds and the semifinals will have a maximum of twenty (20) questions of duration, with no interval (including general questions and bonus).
- c. The final round will have a maximum of forty (40) questions of duration (including general questions and bonus).
- d. The player will have five (5) seconds to begin to answer the general question after pressing the buzzer.
- e. The team will have 25 (twenty-five) seconds to begin to answer the bonus question.
- f. The duration of the round can be extended in case of a tie, as the following:
 1. There will be an extension of one (1) general question to define the winning team of a match.
 2. If the match remains tied after the overtime question, the moderator will use the bonus questions from the round until the tie is broken or until the set of bonus questions is exhausted.
 3. If the game remains tied after the tiebreak questions, the criteria to define the winning team will follow:
 - i. Team with most accumulated points in the competition;
 - ii. Team with the most scoring single member;
 - iii. Team with the lowest average member's age.

6.6. Questions

- a. Each game can have two (2) types of question: general questions (item 6.7), and bonus questions (item 6.8). In the rounds where bonus questions are applicable, the team receives the bonus question whenever a general question is answered correctly, except during the overtime referred to in item 6.5.f .
- b. The quarter-finals will have nine (9) general questions and no bonus questions. The semi-finals and the final will have nine (9) general questions and nine (9) bonus questions each. General questions are worth ten (10) points each, and bonus questions are worth twenty (20) points each.



- c. The questions are selected from a previously created database.
- d. There will be no questions involving calculations.
- e. The questions aim to explore general knowledge in rock mechanics and the like, as well as knowledge of geotechnical community applied to rocks. The questions may include history of rock mechanics, general affairs, current events, technical questions and troubleshooting.
- f. List of some suggested topics as a source of questions (not all included, also check other sources):
 1. Technical material: technical literature on rock mechanics fundamentals, rock mechanics applied to geology engineering, civil works, mining and petroleum geomechanics, which encompass the following topics:
 - i. Mechanical behavior;
 - ii. Field tests;
 - iii. Laboratory tests;
 - iv. Slope stability;
 - v. Underground excavations;
 - vi. Characterization and classification;
 - vii. Geology;
 - viii. Geomechanical modeling;
 - ix. Rock physics;
 - x. Drilling geomechanics;
 - xi. Reservoir geomechanics;
 - xii. Mining.
 2. Non-technical material: the ISRM, general affairs, history, current affairs, statistics, evolution and application of rock mechanics over time in various civilizations, current events.

6.7. General questions

- a. Any form of communication between team players or the audience during the general questions is **prohibited**. Violation of communication rule implies the loss of the right to answer the question. Repeated violations may result in disqualification of the team, as of Ethics and Conduct item.
- b. Team members should not communicate with each other even if the question is being answered by the opposing team.
- c. The player can trigger the buzzer to answer the question at any time after the moderator has started the question.



- d. Once the player presses the buzzer, the game system will report the name of the player so that he/she can answer it.
- e. If a player starts the answer but another member from the same team is recognized by the system, judges may consider “team assistance” (item 6.7.a), and the right to answer the question passes to the other team.
- f. If a player presses the buzzer before the moderator finishes the question reading, this reading stops and the player must start the answer. If the player does not get the answer, the right to answer goes to the opposing team and the moderator reads the question again.
- g. The player has five (5) seconds to give the answer after the activation of the buzzer is recognized. Any answer initiated after the system indicates that the time has expired will not be considered.
- h. Each general question is worth ten (10) points.
- i. If there is no activation of the buzzer after the question reading ends, the moderator shall read the next question.
- j. The general question counts points for the award of the best player.

6.8. Bonus questions

- a. Only the semi-final and final rounds will include bonus questions.
- b. Team members can communicate during the answer period of bonus questions.
- c. Only one player can give the answer agreed by the team.
- d. The team has twenty-five (25) seconds to begin answering after the moderator finishes reading the question. If the team requests that the question be repeated, time continues counting. The answer must be initiated within this time limit.
- e. Each bonus question is worth twenty (20) points.
- f. If the team misses or does not answer the bonus question, it **does not** pass to the opposing team.
- g. The bonus question **does not** count for the best player award.

6.9. Correct answers

- a. Only the first answer given by a player will be accepted.
- b. If a question requires multiple answers, they will be accepted in any order. If either part is wrong, the answer will be given as wrong.
- c. If in doubt about the validity of the answer, the moderator will ask the analysis of the judges, whose decision will be unquestionable.



6.10. Ethics and conduct

- a. All players, institutional representatives (private or governmental) and other people associated with a team, are subject to the code of conduct and behavior in a responsible and ethical manner. This includes:
 1. Treat all participants, organizers and the public with good manners;
 2. Not receive or give unlawful "assistance";
 3. Do not try to fool teammates and officials of the game;
 4. Abide by all decisions of the tournament officials;
 5. Not be an accomplice of another person to "change" the outcome of the game;
 6. Promptly report any violations of conduct to tournament officials.
- b. Teams are prohibited from engaging in promotional activities during the event that seek immediate advantage or provide exposure to brands that are not sponsors of the event. The use of any marketing materials from non-sponsor companies is prohibited, including, but not limited to, clothing, accessories, flags, banners, and similar items. If the judges determine that a team has acted in bad faith during a round, the team will be disqualified.
- c. Any manifestation with nature other than the game purpose such as political, religious and ideological are strictly prohibited, and the person who make it will be requested to leave the tournament. Any person engaging in such conduct will be required to leave the tournament, and if such conduct is carried out by a player, the team will be disqualified.
- d. Any official tournament may denounce the participants and fans of the game in the case of unsuitable behavior during the tournament. The misconduct includes inadequate behavior, unethical behavior or any violation of the code of conduct. Tournament officials may interpret these categories at their discretion.
- e. The major committed and / or repeated infractions may result in expulsion of an individual and / or disqualification of a team at the discretion of tournament officials.
- f. If the judges determine that the competing team has acted in bad faith during its round, the team will be disqualified.